

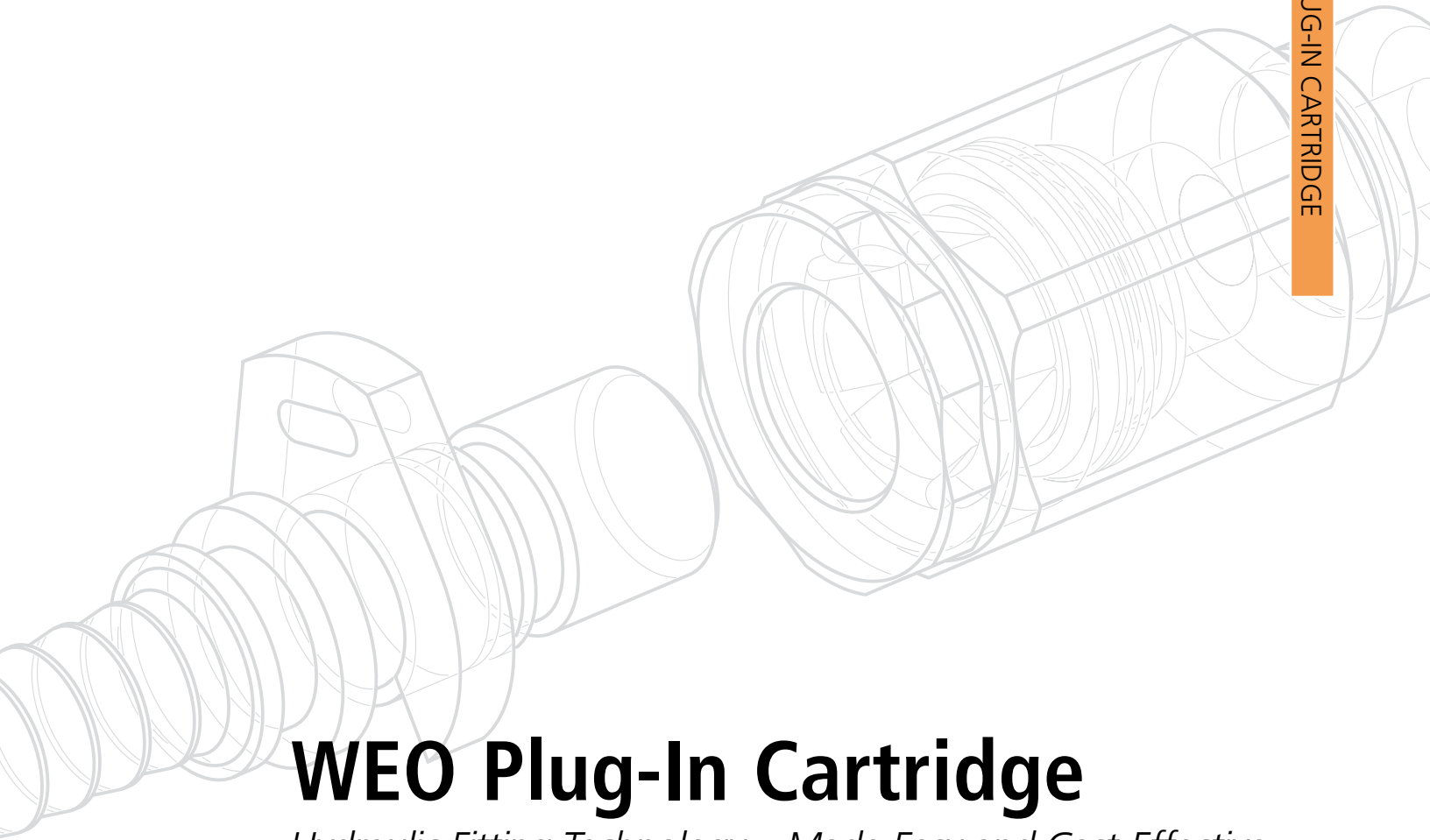

WEO PLUG-IN CARTRIDGE



WEO Plug-In Cartridge

Hydraulic Fitting Technology – Made Easy and Cost-Effective

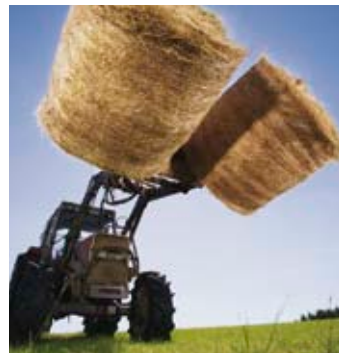



The Flexible Solution

WILL REDUCE YOUR COST

Cut assembly and test times. Make more compact hydraulic components and system designs. Shorten maintenance times and minimize work-related injuries. It all adds up to extensive cost savings for all involved.

PLUG-IN SYSTEMS for hydraulic hose are fast breaking new grounds and more and more equipment and component manufacturers worldwide turn to the WEO Plug-In System to cut both assembly times and space requirements, as well as providing their customers with an equipment made for easy service and minimized downtimes. (See the WEO Plug-In catalog for more information.)

WEO PLUG-IN CARTRIDGE is easily integrated into hydraulic components without interfering with the performance or quality. By using the integrated cartridge you get easy and effective assembly and testing, which will save cost. The innovative cartridge cuts space requirements even more by eliminating the need for adapters or female fittings – just Plug-In!



GET FLEXIBILITY!

WEO Plug-In Cartridge is a flexible cartridge that can be integrated in all kinds of hydraulic components, such as valves, filters, pumps and motors. One cartridge fits all applications, opening up new possibilities for both component and equipment manufacturers. No special design is necessary; just integrate the cartridge into the hydraulic component (see drill pattern illustration on next page).

NEW OPPORTUNITIES!

The WEO Plug-In Cartridge opens up new opportunities where ever you are in the manufacturing chain. Weather you supply the component or the finished equipment, the Cartridge gives you great opportunities to supply an «easy-to-install, easy-to-service» component or machine. Integrating the fitting into the component in an early stage saves time and money every step of the way. No more sub-assemblies or re-tightening of hard to reach screw-fittings or time-consuming leakage tests. Can you think of a better way to support your customer?

CUT YOUR SPACE REQUIREMENTS!

The WEO Plug-In Cartridge gives you new possibilities to design smaller valves, filters, pumps, motors etc. Integrating the fitting means eliminating space requirements for adapters or other fittings. All you need to account for is the space required for a small screwdriver to reach the hose connector. With more and more complex equipment any space savings made means cost savings in the end not to mention a leaner and more attractive piece of equipment. Could you pass up an opportunity like that?



EASY AND EFFECTIVE ASSEMBLY AND TESTING!

The cartridges are delivered on plastic trays, specially developed for automated assembly lines – assuring easy and effective assembly. When integrated testing the component is made as easy as plugging in and out. Integrating the cartridge in the component allows the equipment manufacturer to plug the component into place without sub-assemblies, testing or re-tightening. Saving time and minimizing work-related injuries for both the component and equipment manufacturer. Can you imagine how easy it will be?

EXTRA BENEFITS FOR YOUR CUSTOMERS!

The WEO Plug-In System provides you with an excellent marketing tool. Selling and delivering a ready to plug in component or an easy to service equipment gives you the possibility to bring cost saving technology to your customer, weather it be the next supplier in line or the user of the finished equipment. Could you say no to an offer like that?

A CARTRIDGE WITH MANY POSSIBILITIES FOR YOU!

The WEO Plug-In Cartridge is a product with many possibilities. Flexible – one cartridge fits all applications. Space saving – no extra space for wrenches or cumbersome tools necessary. Timesaving – no need for sub-assemblies of fittings or adapters. Minimizing work injuries – no cumbersome tools or re-tightening necessary. Cutting service times – plug in and out the damaged part in no time. It all adds up to extensive cost savings for you and your customers!

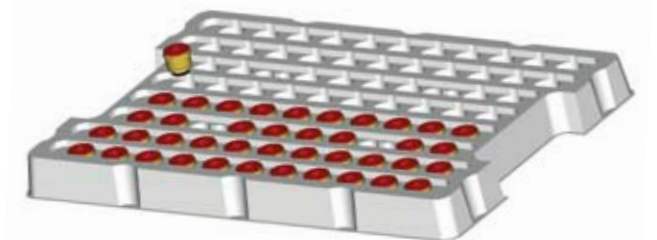

The cartridges are delivered on plastic trays, specially developed for automated assembly lines – assuring easy and effective assembly.

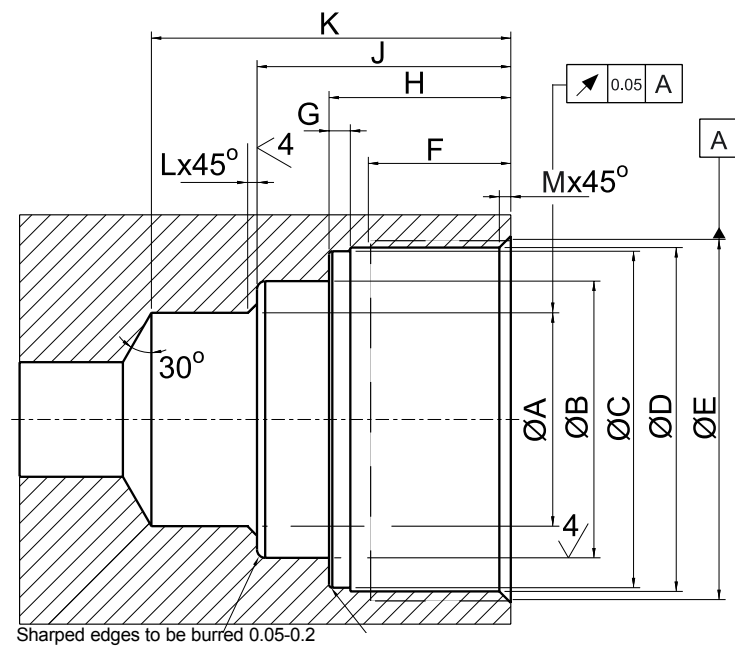
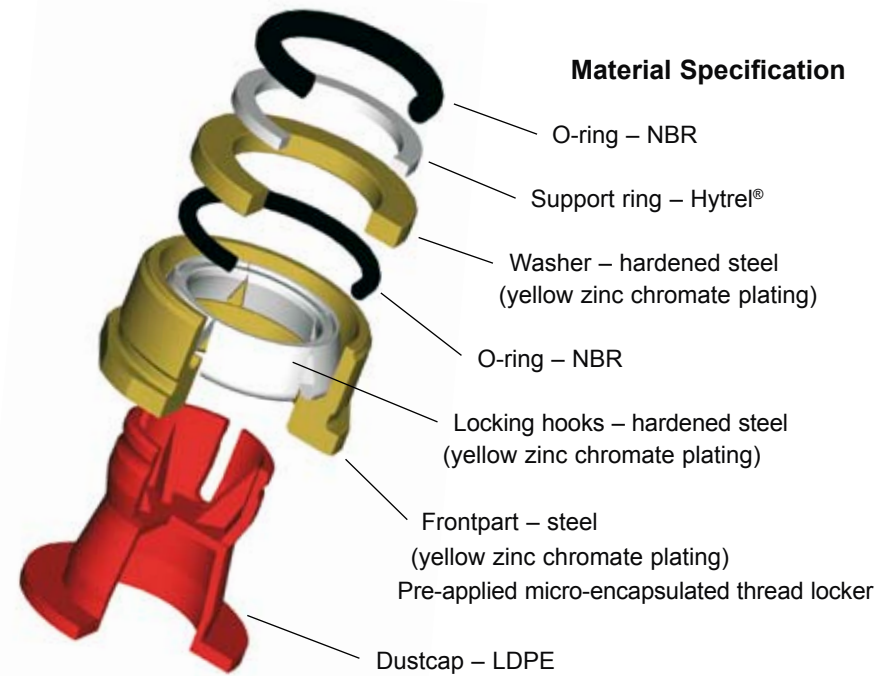

Available sizes:
 DN6 – 14 800 0400
 DN10 – 14 800 0600
 DN12 – 14 800 0800
 DN20 – 14 800 1200

Working Pressure:
 5075 PSI (350 bar)

Burst Pressure:
 20300 PSI (1400 bar)

Temperature Range:
 -22°F to 212°F (-30°C to +100°C)

Part No.	A	B	C	D	E	F	G	H	J	K	L	M	Rec. torque
14 800 0400	10.03+0.08	12.75+0.1	16.55+0.07	17.0+0.1	M18x1	8.5+1	1.1-0.1	10.65+0.1	14.15+0.2	19.65+0.15	0.2	0.7	25-35 Nm
14 800 0600	13.03+0.08	16.95+0.15	20.55+0.07	21.0+0.1	M22x1	8.7+1	1.15-0.1	11.1+0.1	15.5+0.2	21.95+0.15	0.2	0.7	30-40 Nm
14 800 0800	16.03+0.08	19.95+0.15	23.55+0.07	24.0+0.1	M25x1	8.7+1	1.25-0.1	11.3+0.1	15.7+0.2	22.15+0.15	0.3	0.7	40-50 Nm
14 800 1200	23.03+0.08	27.95+0.15	31.05+0.07	31.5+0.1	M33x1.5	11.5+1	1.7-0.1	16.5+0.1	21.4+0.2	31.35+0.15	0.3	1	70-80 Nm

All measurements in mm

CEJN reserves the right to make changes without further notification.

Extensive Benefits and Cost Savings for Everyone!

The WEO Plug-In Cartridge will save time, space and cost for everyone in the manufacturing chain.



EQUIPMENT MANUFACTURERS

Using components with integrated WEO Plug-In cartridges will make your assembly easier and faster. You no longer need to assemble adapters or female fittings before attaching the hose or to re-tighten the hose fittings after assembly, thus also minimizing work-related injuries. The WEO Plug-In click-to-connect feature also opens up for more compact system designs. Adding up to extensive cost savings!



COMPONENT MANUFACTURERS

Integrating the WEO Plug-In Cartridge in your components means selling and delivering cost saving benefits to your customer. With no adapters or female fittings necessary for assembly you'll also make your own testing procedures quick and easy without compromising quality. Adding up to cost savings and new business opportunities!



The Global

Quick Connect Specialist

CEJN Industrial Corporation

212 Ambrogio Drive

Gurnee, IL 60031

Telephone: 847-263-7200

Fax: 847-263-7207

email: customer.service@cejn.com

www.cejn.us